



**KERNEBREMASKINE**
**PROFIBASIC**

MABasic 35

Optagen effekt (Watt)	1.050
Volt	230
Omdrejningstal (min-1)	450
Vandring (mm.)	160
Magnet størrelse i mm. (B x L x H)	84 x 168 x 48
Kernebor kort 30 mm. lang 55 mm.	12-35 12-35
Tilslutning	19 mm Weldon (3/4")
Permanent indvendig smøring	✓
Vægt (kg)	12,0
Art. nr.	MABasic35
DKK	5.100,00
Lager	✓

**KERNEBREMASKINE**
**PROFIBASIC**

MABasic 50

Optagen effekt (Watt)	1.150
Volt	230
Omdrejningstal (o/min)	Gear 1: 250 Gear 2: 450
Vandring (mm.)	160
Kernebor kort 30 mm. lang 55 mm.	12-50 12-50
Max. boreddybde i stål (mm.)	55
Spiralbor max. Ø (mm.)	18
Tilslutning	MK2
Permanent indvendig smøring	✓
Vægt (kg)	13,0
Art. nr.	MABasic 50
DKK	9.500,00
Lager	✓

**KERNEBOREMASKINE**
**PROFIBASIC**

MABasic 200

Optagen effekt (Watt)	900
Volt	230
Omdrejningstal (o/min)	450
Vandring (mm.)	160
Magnet størrelse i mm. (B x L x H)	84 x 168 x 48
Kernebor kort 30 mm. lang 55 mm.	12-32 12-32
Spiralbor (max. Ø mm.)	op til 13
Max. boreddybde i stål (mm.)	30/55
Kerneborepatron	19 mm Weldon (3/4")
Indvendig smøring	✓
Vægt (kg)	12,00
Art. nr.	MABasic 200
DKK	6.700,00
Lager	✓

**KERNEBOREMASKINE**
**PROFIBASIC**

MABasic 400

Optagen effekt (Watt)	1.050
Volt	230
Omdrejningstal (o/min)	430 760
Vandring (mm.)	160
Magnet størrelse i mm. (B x L x H)	84 x 160 x 41,5
Kernebor kort 30 mm. lang 55 mm.	12-35 12-35
Spiralbor (max. Ø mm.)	op til 16
Max. boreddybde i stål (mm.)	35
Kerneborepatron	19 mm Weldon (3/4")
Indvendig smøring	✓
Vægt (kg)	12,0
Art. nr.	MABasic 400
DKK	11.200,00
Lager	✓



MABasic 450

Optagen effekt (Watt)	1.150
Volt	230
Omdrejningstal (o/min)	250 450
Vandring (mm.)	160
Magnet størrelse i mm. (B x L x H)	84 x 168 x 41,5
Kernebor kort 30 mm. lang 55 mm.	12-40 12-40
Spiralbor (max. Ø mm.)	op til 18
Max. boreddybde i stål (mm.)	30/55
Kerneborepatron	MK2, 19 mm Weldon (3/4")
Indvendig smøring	✓
Vægt (kg)	13,0
Art. nr.	MABasic 450
DKK	11.900,00
Lager	✓



MABasic 850

Optagen effekt (Watt)	1.800
Volt	230
Omdrejningstal (o/min)	Gear 1: 110 Gear 2: 175 Gear 3: 425 Gear 4: 385
Vandring (mm.)	255
Magnet størrelse i mm. (B x L x H)	110 x 220 x 54
Kernebor kort 30 mm. lang 55 mm. lang 75 mm ekstra lang 110 mm.	12 - 75 2 - 75 18 - 60 20 - 60
Spiralbor (max. Ø mm.)	31,75
Max. boreddybde i stål (mm.)	110
Kerneborepatron	MK 3, 19 mm Weldon (3/4") MK 3, 32 mm Weldon (1 1/4")
Spindelkonus	MK 3
Indvendig smøring	✓
Vægt (kg)	24,0
Art. nr.	MABasic 850
DKK	14.950,00
Lager	✓

**KERNEBREMASKINE**
**PROFISTART**

MAB 100.1K

Optagen effekt (Watt)	800
Volt	230
Omdrejningstal (o/min)	450
Vandring (mm.)	70
Magnet størrelse i mm. (B x L x H)	80 x 160 x 41,5
Kernebor kort 30 mm. lang 55 mm.	12-30 12-30
Max. boreddybde i stål (mm.)	30
Kerneborepatron	KEYLESS, 19 mm Weldon (3/4")
Permanent indvendig smøring	✓
Vægt (kg)	9,9
Art. nr.	MAB 100.1K
DKK	9.200,00
Lager	✓

**KERNEBREMASKINE**
**PROFISPEZIAL**

MAB 155 SP

Optagen effekt (Watt)	1.050
Volt	230
Omdrejningstal (o/min)	460
Vandring (mm.)	39
Magnet størrelse i mm. (B x L x H)	80 x 160 x 36,5
Kernebor kort 30 mm.	12-35
Max. boreddybde i stål (mm.)	30
Kerneborepatron	19 mm Weldon (3/4")
Permanent indvendig smøring	✓
Vægt (kg)	11,0
Art. nr.	MAB 155 SP
DKK	12.400,00
Lager	✓

**KERNEBREMASKINE**
**PROFISTART**

MAB 455

Optagen effekt (Watt)	1.150
Volt	230
Omdrejningstal (o/min)	250 450
Vandring (mm.)	160
Magnet størrelse i mm. (B x L x H)	84 x 168 x 41,5
Kernebor kort 30 mm. lang 55 mm.	12-40 12-40
Max. boreddybde i stål (mm.)	30/55
Spiralbor max. Ø (mm.)	18
Tilslutning	KEYLESS, 19 mm Weldon (3/4")
Spindelkonus	MK 2
Permanent indvendig smøring	✓
Vægt (kg)	13,0
Art. nr.	MAB 455
DKK	15.200,00
Lager	✓

## KERNEBREMASKINE

## PROFIPLUS



MAB 485

Optagen effekt (Watt)	1.150
Volt	230
Omdrejningstal (o/min)	50 - 250 100 - 450
Vandring (mm.)	160
Magnet størrelse i mm. (B x L x H)	84 x 168 x 41,5
Kernebor kort 30 mm. lang 55 mm.	12 - 40 12 - 40
Max. boreddybde i stål (mm.)	30/55
Spiralbor max. Ø (mm.)	18
Forsænker max. Ø (mm.)	40
Oprømning max. Ø (mm.)	18
Gevindskæring	M8 - M16
Tilslutning	KEYLESS, 19 mm Weldon (3/4")
Spindelkonus	MK 2
Permanent indvendig smøring	✓
Vægt (kg)	13,0
Art. nr.	MAB 485
DKK	16.300,00
Lager	✓

## KERNEBREMASKINE

## PROFIPLUS



MAB 525

Optagen effekt (Watt)	1.600
Volt	230
Omdrejningstal (o/min)	70-280 180-580
Vandring (mm.)	160
Magnet størrelse i mm. (B x L x H)	90 x 180 x 48
Kernebor kort 30 mm. lang 55 mm.	12 - 50 12 - 50
Max. boreddybde i stål (mm.)	30/55
Spiralbor max. Ø (mm.)	20
Forsænker max. Ø (mm.)	50
Oprømning max. Ø (mm.)	20
Gevindskæring	M20
Tilslutning	KEYLESS, 19 mm Weldon (3/4")
Spindelkonus	MK 3
Permanent indvendig smøring	✓
Vægt (kg)	16,0
Art. nr.	MAB 525
DKK	18.200,00
Lager	✓

**KERNEBOREMASKINE**
**PROFIPLUS**

MAB 825

Optagen effekt (Watt)		1.800
Volt		230
Omdrejningstal (o/min)		40-110 65-175 140-360 220-600
Vandring (mm.)		255
Magnet størrelse i mm. (B x L x H)		110 x 220 x 54
Kernebor kort	30 mm.	12 - 100
lang	55 mm.	12 - 100
lang	75 mm	18 - 60
ekstra lang	110 mm.	20 - 60
Max. boreddybde i stål (mm.)		30/55 <sup>(1)</sup> 110 <sup>(2)</sup>
Spiralbor max. Ø (mm.)		31,75
Forsænker max. Ø (mm.)		50
Oprømning max. Ø (mm.)		31,75
Gevindskæring		M30
Tilslutning		MK 3, 32 mm Weldon (1 1/4") KEYLESS, 19 mm Weldon (3/4")
Spindelkonus		MK 3
Permanent indvendig smøring		✓
Vægt (kg)		25,0
Art. nr.		MAB 825
DKK		24.200,00
Lager		✓

**KERNEBOREMASKINE**
**AUTOMATISK TILSPÆNDING**
**PROFISPEZIAL**

MAB 825V

Optagen effekt (Watt)		1.800
Volt		230
Omdrejningstal (o/min)		40-110 65-175 140-360 220-600
Vandring (mm.)		255
Magnet størrelse i mm. (B x L x H)		110 x 220 x 54
Kernebor	<b>(Automatisk tilspændning)</b>	
kort	30 mm.	12 - 60
lang	55 mm.	12 - 60
Kernebor	<b>(Manuel tilspændning)</b>	
kort	30 mm.	12 - 100
lang	55 mm.	12 - 100
Max. boreddybde i stål mm.		30/55
Spiralbor max. Ø mm.	<b>(Manuel tilspændning)</b>	31,75
Spiralbor max. Ø mm.	<b>(Automatisk tilspændning)</b>	26
Forsænker max. Ømm.	<b>(Manuel tilspændning)</b>	50
Oprømning max. Ø mm.	<b>(Automatisk tilspændning)</b>	31,75
Gevindskæring	<b>(Manuel tilspændning)</b>	M30
Tilslutning		MK 3, 32 mm Weldon (1 1/4") KEYLESS, 19 mm Weldon (3/4")
Spindelkonus		MK 3
Permanent indvendig smøring		✓
Vægt (kg)		34,0
Art. nr.		MAB 825V
DKK		53.600,00
Lager		✓

**KERNEBREMASKINE**
**PROFIPLUS**

MAB 845

Optagen effekt (Watt)		1.800
Volt		230
Omdrejningstal (o/min)		40-110 65-175 140-360 220-600
Vandring (mm.)		255
Magnet størrelse i mm. (B x L x H)		110 x 220 x 54
Kernebor kort	30 mm.	12 - 100
lang	55 mm.	12 - 100
lang	75 mm	18 - 60
ekstra lang	110 mm.	20 - 60
Max. boreddybde i stål (mm.)		30/55 <sup>(1)</sup> 110 <sup>(2)</sup>
Spiralbor max. Ø (mm.)		31,75
Forsænker max. Ø (mm.)		50
Oprømning max. Ø (mm.)		31,75
Gevindskæring		M30
Tilslutning		MK 3, 32 mm Weldon (1 1/4") KEYLESS, 19 mm Weldon (3/4")
Spindelkonus		MK 3
Permanent indvendig smøring		✓
Vægt (kg)		25,0
Art. nr.		MAB 845
DKK		25.400,00
Lager		✓

**KERNEBREMASKINE**
**AUTOMATISK TILSPÆNDNING**
**PROFISPEZIAL**

MAB 845 V

Optagen effekt (Watt)		1.800
Volt		230
Omdrejningstal (o/min)		40-110 65-175 140-360 220-600
Vandring (mm.)		255
Magnet størrelse i mm. (B x L x H)		110 x 220 x 54
Kernebor	<b>(Automatisk tilspændning)</b>	
kort	30 mm.	12-60
lang	55 mm.	12-60
Kernebor	<b>(Manuel tilspændning)</b>	
kort	30 mm.	12-100
lang	55 mm.	12-100
Max. boreddybde i stål mm.		30/55
Spiralbor max. Ø mm.	<b>(Manuel tilspændning)</b>	31,75
Spiralbor max. Ø mm.	<b>(Automatisk tilspændning)</b>	26
Forsænker max. Ø mm.	<b>(Manuel tilspændning)</b>	50
Oprømning max Ø mm.	<b>(Automatisk tilspændning)</b>	31,75
Gevindskæring	<b>(Manuel tilspændning)</b>	M30
Tilslutning		MK 3, 32 mm Weldon (1 1/4") KEYLESS, 19 mm Weldon (3/4")
Spindelkonus		MK 3
Permanent indvendig smøring		✓
Vægt (kg)		34,0
Art. nr.		MAB 845 V
DKK		58.100,00
Lager		÷





MAB 1300

Optagen effekt (Watt)		2.300
Volt		230
Omdrejningstal (o/min)		30-80 50-120 130-350 210-550
Vandring (mm.)		85/310
Magnet størrelse i mm. (B x L x H)		120 x 360 x 67
Kernebor kort	30 mm.	12-130
lang	55 mm.	12-130
lang	75 mm	18-120
ekstra lang	110 mm.	20-120
Max. boreddybde i stål (mm.)		30 55 110
Spiralbor max. Ø (mm.)		45
Forsænker max. Ø (mm.)		80
Oprømning max Ø (mm.)		50
Gevindskæring		M42
Tilslutning		32 mm Weldon (1 1/4")
Spindelkonus		MK4
Permanent indvendig smøring		✓
Vægt (kg)		51,0
Art. nr.		MAB 1300
DKK		44.700,00
Lager		✓



MAB 1300 V

**Manuel eller automatisk  
tilspændning**

Optagen effekt (Watt)		2.300
Volt		230
Omdrejningstal (o/min)		30-80 50-120 130-350 210-550
Vandring (mm.)		310
Magnet størrelse i mm. (B x L x H)		120 X 360 X 67 mm
Kernebor	<b>(Automatisk tilspændning)</b>	
kort	30 mm.	12-60
lang	55 mm.	12-60
ekstra lang	110 mm.	20-60
Kernebor	<b>(Manuel tilspændning)</b>	
kort	30 mm.	12-130
lang	55 mm.	12-100
ekstra lang	110 mm.	20-100
Spiralbor max. Ø mm.	<b>(Manuel tilspændning)</b>	45
Spiralbor max. Ø mm.	<b>(Automatisk tilspændning)</b>	32
Forsænker max. Ø mm.	<b>(Manuel tilspændning)</b>	80
Oprømning max Ø mm.	<b>(Automatisk tilspændning)</b>	50
Gevindskæring	<b>(Manuel tilspændning)</b>	M42
Tilslutning		19 mm og 32 mm Weldon (1 1/4")
Spindelkonus		MK4
Permanent indvendig smøring		✓
Vægt (kg)		51,0
Art. nr.		MAB 1300 V
DKK		76.200,00
Lager		✓

**KERNEBREMASKINE****AUTOMATISK TILSPÆNDING****PROFISPEZIAL**

AutoMAB 350

Optagen effekt (Watt)	1.050
Volt	230
Omdrejningstal (o/min)	360
Vandring (mm.)	150
Magnet størrelse i mm. (B x L x H)	84 x 168 x 48
Kernebor kort 30 mm.	12-35
Kernebor lang 55 mm.	12-35
Tilslutning	19 mm Weldon (3/4")
Permanent indvendig smøring	✓
Vægt (kg)	15,0
Art. nr.	AutoMAB 350
DKK	14.200,00
Lager	✓

**KERNEBREMASKINE****AUTOMATISK TILSPÆNDING****PROFISPEZIAL**

AutoMAB 450

Optagen effekt (Watt)	1.150
Volt	230
Omdrejningstal (o/min)	250 450
Vandring (mm.)	150
Magnet størrelse i mm. (B x L x H)	84 x 168 x 48
Kernebor kort 30 mm.	12-45
Kernebor lang 55 mm.	12-45
Tilslutning	MK2 ,19 mm Weldon (3/4")
Permanent indvendig smøring	✓
Vægt (kg)	16,0
Art. nr.	AutoMAB 450
DKK	16.100,00
Lager	✓

**KERNEBREMASKINE****LUFT****PROFISPEZIAL**

AirMAB 5000

Optagen effekt (Watt)	830
Omdrejningstal (o/min)	min. 290 max. 575
Vandring (mm)	160
Nominelt drejningsmoment (Nm)	27
Luft (l/min)	1000
Magnet størrelse i mm. (B x L x H)	90 x 190 x 60
Kernebor kort 30 mm.	12-35
lang 55 mm.	12-35
Max. boreddybde i stål (mm)	30
Spiralbor max. Ø (mm.)	23
Tilslutning	KEYLESS, 19 mm Weldon (3/4")
Spindelkonus	MK2
Permanent indvendig smøring	✓
Vægt (kg)	17,5
Art. nr.	AirMAB 5000
DKK	46.700,00
Lager	÷



PipeMAB 200

Optagen effekt (Watt)	1.050
Volt	230
Omdrejningstal (min-1)	450
Vandring (mm.)	160
Magnet størrelse i mm. (B x L x H)	191 x 266 x 88
Boreddybde max. (mm)	40
Kernebor længde (mm)	32
Tilslutning	19 mm Weldon
Permanent indvendig smøring	✓
Vægt (kg)	16,0
Art. nr.	PIPEMAB200
DKK	19.300,00
Lager	✓



**Monteres på rør  
fra 85 mm**



PipeMAB 525

Optagen effekt (Watt)	1.600
Volt	230
Omdrejningstal (min-1)	Gear 1: 70-280 Gear 2: 180-580
Vandring (mm.)	160
Magnet størrelse i mm. (B x L x H)	191 x 266 x 88
Boreddybde max. (mm)	40
Kernebor længde (mm)	50
Spiralbor (mm)	20
Gevind	M20
Tilslutning	MK3
Permanent indvendig smøring	✓
Vægt (kg)	19,5
Art. nr.	PIPEMAB525
DKK	26.700,00
Lager	✓



**Monteres på rør  
fra 85 mm**

**TOGSKINNE BOREMASKINE**
**PROFISPEZIAL**

RailMAB 915

Optagen effekt (Watt)	1.600
Volt	230
Omdrejningstal (o/min)	70-280 180-580
Vandring (mm.)	160
Kernebor Ø (mm)	17-36
Tilslutning	KEYLESS, 19 mm Weldon (3/4")
Spindelkonus	MK3
Permanent indvendig smøring	✓
Køling	Kølemiddel
Vægt (kg)	17,0
Art. nr.	RailMAB 915
DKK	40.000,00
Lager	÷

**TOGSKINNE BOREMASKINE**
**PROFISPEZIAL**

RailMAB 965

Motor	Benzin
Afgiven effekt (KW)	1,5
Omdrejningstal (o/min)	Minium 110 Maxium 280
Kapacitet (ccm)	49,4
Benzintank (L)	0,5
Vandring (mm.)	40
Drejningsmoment (Nm)	3,04
Kernebor Ø (mm.)	17 - 36
Kernebor kort (mm.)	30
Tilslutning	direkte 19 mm Weldon (3/4")
Vægt (kg)	21,5
Permanent indvendig smøring	✓
Køling	Kølemiddel
Art. nr.	RailMAB 965
DKK	39.000,00
Lager	÷

## TILBEHØR



ZMC 200

Bordplade mål (mm)	370 x 240 x 88
Magnet størrelse i mm. (H x B)	90 x 180
Materiale	stål / aluminium
Vægt (kg)	3,5
Art. nr.	ZMC 200
DKK	3.100,00
Lager	✓

## TILBEHØR



beskrivelse	Art. nr.	DKK	Lager
Power Worker (spån opsamler)	POW 100	545,00	✓
Power Cleaner (spån renser)	POW 200	545,00	✓

## KERNEBOR SÆT





beskrivelse	Art. nr.	DKK	Lager
KBK 013-014-017-018-021-022 x 1 Centerstift ZAK 075 x 1 Skæredybde 30 mm	KBK 002	1.649,00	✓
HKK HM 013-014-017-018-021-022 x 1 Centerstift ZAK 075 x 1 Skæredybde 30 mm HKK HM 005	HKK 002	2.760,00	✓

**SPIRALBOR HSS**

Spiralbor HSS 6 - 14 mm med 19 mm Weldon skaft.

Spiral længde 35 mm.

	Art. nr.	DKK	Lager
6,0	SPS 060	161,00	✓
6,8	SPS 068	166,00	✓
8,0	SPS 080	171,00	✓
8,5	SPS 085	173,00	✓
10,0	SPS 100	176,00	✓

	Art. nr.	DKK	Lager
10,2	SPS 102	176,00	✓
12,0	SPS 120	205,00	✓
13,0	SPS 130	247,00	✓
14,0	SPS 140	251,00	✓

**KBK HSS****Kort****STANDARD**

KBK Kernebor HSS 12 - 60 mm med 19 mm Weldon skaft.

Skæredybde 30 mm.

	Art. nr.	DKK	Lager
12	KBK 012	190,00	✓
13	KBK 013	197,00	✓
14	KBK 014	181,00	✓
15	KBK 015	212,00	✓
16	KBK 016	215,00	✓
17	KBK 017	223,00	✓
17,5	KBK 175	262,00	✓
18	KBK 018	212,00	✓
19	KBK 019	234,00	✓
19,5	KBK 195	288,00	✓
20	KBK 020	246,00	✓
21	KBK 021	262,00	✓
22	KBK 022	257,00	✓
23	KBK 023	282,00	✓
24	KBK 024	291,00	✓
25	KBK 025	298,00	✓
26	KBK 026	293,00	✓
27	KBK 027	321,00	✓
28	KBK 028	332,00	✓
29	KBK 029	341,00	✓
30	KBK 030	353,00	✓
31	KBK 031	349,00	✓
32	KBK 032	369,00	✓
33	KBK 033	392,00	✓
34	KBK 034	459,00	✓
35	KBK 035	504,00	✓

	Art. nr.	DKK	Lager
36	KBK 036	538,00	✓
37	KBK 037	545,00	✓
38	KBK 038	543,00	✓
39	KBK 039	568,00	✓
40	KBK 040	585,00	✓
41	KBK 041	656,00	✓
42	KBK 042	685,00	✓
43	KBK 043	711,00	✓
44	KBK 044	757,00	✓
45	KBK 045	773,00	✓
46	KBK 046	796,00	✓
47	KBK 047	820,00	✓
48	KBK 048	838,00	✓
49	KBK 049	864,00	✓
50	KBK 050	891,00	✓
51	KBK 051	953,00	✓
52	KBK 052	998,00	✓
53	KBK 053	1.123,00	✓
54	KBK 054	1.144,00	✓
55	KBK 055	1.185,00	✓
56	KBK 056	1.233,00	✓
57	KBK 057	1.258,00	✓
58	KBK 058	1.295,00	✓
59	KBK 059	1.320,00	✓
60	KBK 060	1.352,00	✓

**CENTRERSTIFT**

Størrelse	Art. nr.	DKK	Lager
Ø 12 - 60 mm	ZAK 075	81,00	✓



KBK Kernebor HSS-E 61 - 130 mm med 32 mm Weldon skaft.

Skæredybde 30 mm.

	Art. nr.	DKK	Lager
61	KBK-CO 061	2.193,00	✓
62	KBK-CO 062	2.202,00	✓
63	KBK-CO 063	2.221,00	✓
64	KBK-CO 064	2.232,00	✓
65	KBK-CO 065	2.247,00	✓
66	KBK-CO 066	2.262,00	✓
67	KBK-CO 067	2.277,00	✓
68	KBK-CO 068	2.281,00	✓
69	KBK-CO 069	2.306,00	✓
70	KBK-CO 070	2.344,00	✓
71	KBK-CO 071	2.395,00	✓
72	KBK-CO 072	2.454,00	✓
73	KBK-CO 073	2.499,00	✓
74	KBK-CO 074	2.529,00	✓
75	KBK-CO 075	2.578,00	✓
76	KBK-CO 076	2.625,00	✓
77	KBK-CO 077	2.677,00	✓
78	KBK-CO 078	2.714,00	✓
79	KBK-CO 079	2.756,00	✓
80	KBK-CO 080	2.803,00	✓
81	KBK-CO 081	2.832,00	✓
82	KBK-CO 082	2.877,00	✓

	Art. nr.	DKK	Lager
83	KBK-CO 083	2.919,00	÷
84	KBK-CO 084	2.963,00	÷
85	KBK-CO 085	2.992,00	✓
86	KBK-CO 086	3.044,00	÷
87	KBK-CO 087	3.089,00	÷
88	KBK-CO 088	3.149,00	÷
89	KBK-CO 089	3.195,00	÷
90	KBK-CO 090	3.218,00	✓
91	KBK-CO 091	3.267,00	÷
92	KBK-CO 092	3.315,00	÷
93	KBK-CO 093	3.352,00	÷
94	KBK-CO 094	3.388,00	÷
95	KBK-CO 095	3.425,00	✓
96	KBK-CO 096	3.467,00	÷
97	KBK-CO 097	3.507,00	÷
98	KBK-CO 098	3.551,00	✓
99	KBK-CO 099	3.596,00	÷
100	KBK-CO 100	3.667,00	✓
110	KBK-CO 110	4.809,00	✓
120	KBK-CO 120	5.087,00	✓
130	KBK-CO 130	5.343,00	✓

## CENTRERSTIFT



Størrelse	Art. nr.	DKK	Lager
Ø 61 - 130 mm	ZAK 090	96,00	✓



KBL Kernebor HSS 12 - 60 mm med 19 mm Weldon skaft.

Skæredybde 55 mm.

	Art. nr.	DKK	Lager
12	KBL 012	246,00	✓
13	KBL 013	254,00	✓
14	KBL 014	233,00	✓
15	KBL 015	268,00	✓
16	KBL 016	287,00	✓
17	KBL 017	298,00	✓
17,5	KBL 175	380,00	✓
18	KBL 018	284,00	✓
19	KBL 019	338,00	✓
19,5	KBL 195	432,00	✓
20	KBL 020	353,00	✓
21	KBL 021	360,00	✓
22	KBL 022	360,00	✓
23	KBL 023	391,00	✓
24	KBL 024	407,00	✓
25	KBL 025	415,00	✓
26	KBL 026	420,00	✓
27	KBL 027	456,00	✓
28	KBL 028	469,00	✓
29	KBL 029	483,00	✓
30	KBL 030	496,00	✓
31	KBL 031	518,00	✓
32	KBL 032	529,00	✓
33	KBL 033	540,00	✓
34	KBL 034	554,00	✓
35	KBL 035	573,00	✓

	Art. nr.	DKK	Lager
36	KBL 036	616,00	✓
37	KBL 037	625,00	✓
38	KBL 038	647,00	✓
39	KBL 039	660,00	✓
40	KBL 040	674,00	✓
41	KBL 041	736,00	✓
42	KBL 042	750,00	✓
43	KBL 043	769,00	✓
44	KBL 044	789,00	✓
45	KBL 045	816,00	✓
46	KBL 046	845,00	✓
47	KBL 047	887,00	✓
48	KBL 048	903,00	✓
49	KBL 049	927,00	✓
50	KBL 050	952,00	✓
51	KBL 051	1.072,00	✓
52	KBL 052	1.167,00	✓
53	KBL 053	1.219,00	✓
54	KBL 054	1.265,00	✓
55	KBL 055	1.308,00	✓
56	KBL 056	1.350,00	✓
57	KBL 057	1.388,00	✓
58	KBL 058	1.432,00	✓
59	KBL 059	1.481,00	✓
60	KBL 060	1.519,00	✓

## CENTRERSTIFT



Størrelse	Art. nr.	DKK	Lager
Ø 12 - 60 mm	ZAK 100	102,00	✓





KBL Kernebor HSS-E 61 - 100 mm med 32 mm Weldon skaft.

Skæredybde 55 mm.

		Art. nr.	DKK	Lager
61		KBL-CO 061	2.484,00	÷
62		KBL-CO 062	2.507,00	÷
63		KBL-CO 063	2.529,00	÷
64		KBL-CO 064	2.548,00	÷
65		KBL-CO 065	2.570,00	√
66		KBL-CO 066	2.602,00	÷
67		KBL-CO 067	2.674,00	÷
68		KBL-CO 068	2.737,00	÷
69		KBL-CO 069	2.799,00	÷
70		KBL-CO 070	2.844,00	√
71		KBL-CO 071	2.881,00	÷
72		KBL-CO 072	2.919,00	÷
73		KBL-CO 073	2.980,00	÷
74		KBL-CO 074	3.040,00	÷
75		KBL-CO 075	3.104,00	√
76		KBL-CO 076	3.143,00	√
77		KBL-CO 077	3.186,00	÷
78		KBL-CO 078	3.216,00	÷
79		KBL-CO 079	3.244,00	÷
80		KBL-CO 080	3.292,00	√

		Art. nr.	DKK	Lager
81		KBL-CO 081	3.337,00	÷
82		KBL-CO 082	3.379,00	÷
83		KBL-CO 083	3.422,00	÷
84		KBL-CO 084	3.478,00	÷
85		KBL-CO 085	3.507,00	√
86		KBL-CO 086	3.549,00	÷
87		KBL-CO 087	3.556,00	÷
88		KBL-CO 088	3.570,00	÷
89		KBL-CO 089	3.581,00	÷
90		KBL-CO 090	3.640,00	√
91		KBL-CO 091	3.667,00	÷
92		KBL-CO 092	3.704,00	÷
93		KBL-CO 093	3.745,00	÷
94		KBL-CO 094	3.760,00	÷
95		KBL-CO 095	3.785,00	√
96		KBL-CO 096	3.841,00	÷
97		KBL-CO 097	3.890,00	÷
98		KBL-CO 098	3.923,00	÷
99		KBL-CO 099	3.949,00	÷
100		KBL-CO 100	3.964,00	√

## CENTRERSTIFT



Størrelse	Art. nr.	DKK	Lager
Ø 61 - 130 mm	ZAK 120	113,00	√



KEL Kernebor HSS Ekstra lang (110 mm) 20 - 50 mm med 19 mm Weldon skaft.

Skæredybde 110 mm.

	Art. nr.	DKK	Lager
20	KEL 020	1.034,00	✓
21	KEL 021	1.098,00	✓
22	KEL 022	1.291,00	✓
23	KEL 023	1.297,00	✓
24	KEL 024	1.342,00	✓
25	KEL 025	1.439,00	✓
26	KEL 026	1.499,00	✓
27	KEL 027	1.612,00	✓
28	KEL 028	1.808,00	✓
29	KEL 029	1.885,00	✓
30	KEL 030	1.947,00	✓
31	KEL 031	1.956,00	✓
32	KEL 032	1.982,00	✓
33	KEL 033	2.192,00	✓
34	KEL 034	2.457,00	✓
35	KEL 035	2.628,00	✓

	Art. nr.	DKK	Lager
36	KEL 036	2.809,00	✓
37	KEL 037	2.976,00	✓
38	KEL 038	3.287,00	✓
39	KEL 039	3.458,00	✓
40	KEL 040	3.620,00	✓
41	KEL 041	3.801,00	÷
42	KEL 042	3.966,00	✓
43	KEL 043	4.162,00	÷
44	KEL 044	4.342,00	✓
45	KEL 045	4.496,00	✓
46	KEL 046	4.764,00	÷
47	KEL 047	4.944,00	÷
48	KEL 048	5.005,00	÷
49	KEL 049	5.221,00	÷
50	KEL 050	5.397,00	✓

## CENTRERSTIFT





Størrelse	Art. nr.	DKK	Lager
Ø 20 - 50 mm	ZAK 275	267,00	✓



HSS-Co 8-F Kernebor 12 - 60 mm med FEIN QuickIN skaft.

Skæredybde 35 mm.

	Art. nr.	DKK	Lager
12	KBK-F 012	342,00	÷
13	KBK-F 013	359,00	÷
14	KBK-F 014	329,00	÷
15	KBK-F 015	386,00	÷
16	KBK-F 016	399,00	÷
17	KBK-F 017	412,00	÷
18	KBK-F 018	384,00	÷
19	KBK-F 019	380,00	÷
20	KBK-F 020	462,00	÷
21	KBK-F 021	488,00	÷
22	KBK-F 022	483,00	÷
23	KBK-F 023	522,00	÷
24	KBK-F 024	535,00	÷
25	KBK-F 025	574,00	÷
26	KBK-F 026	561,00	÷
27	KBK-F 027	609,00	÷
28	KBK-F 028	628,00	÷
29	KBK-F 029	644,00	÷
30	KBK-F 030	683,00	÷
31	KBK-F 031	706,00	÷
32	KBK-F 032	725,00	÷
33	KBK-F 033	757,00	÷
34	KBK-F 034	876,00	÷
35	KBK-F 035	972,00	÷
36	KBK-F 036	1.024,00	÷

	Art. nr.	DKK	Lager
37	KBK-F 037	1.042,00	÷
38	KBK-F 038	1.053,00	÷
39	KBK-F 039	1.081,00	÷
40	KBK-F 040	1.124,00	÷
41	KBK-F 041	1.176,00	÷
42	KBK-F 042	1.236,00	÷
43	KBK-F 043	1.271,00	÷
44	KBK-F 044	1.346,00	÷
45	KBK-F 045	1.394,00	÷
46	KBK-F 046	1.433,00	÷
47	KBK-F 047	1.467,00	÷
48	KBK-F 048	1.493,00	÷
49	KBK-F 049	1.532,00	÷
50	KBK-F 050	1.590,00	÷
51	KBK-F 051	1.693,00	÷
52	KBK-F 052	1.769,00	÷
53	KBK-F 053	1.976,00	÷
54	KBK-F 054	1.998,00	÷
55	KBK-F 055	2.078,00	÷
56	KBK-F 056	2.140,00	÷
57	KBK-F 057	2.192,00	÷
58	KBK-F 058	2.252,00	÷
59	KBK-F 059	2.294,00	÷
60	KBK-F 060	2.342,00	÷

## CENTRERSTIFT



Størrelse	Art. nr.	DKK	Lager
Ø 12 - 60 mm	ZAK 096	135,00	✓



HKKN kernebor HM 12 - 60 mm med 19 mm med combi skaft (Weldon og Nitto).

Skæredybde 30 mm.

		Art. nr.	DKK	Lager
12		HKKN 012	453,00	✓
13		HKKN 013	460,00	✓
14		HKKN 014	468,00	✓
15		HKKN 015	481,00	✓
16		HKKN 016	481,00	✓
17		HKKN 017	483,00	✓
18		HKKN 018	483,00	✓
19		HKKN 019	487,00	✓
20		HKKN 020	487,00	✓
21		HKKN 021	490,00	✓
22		HKKN 022	490,00	✓
23		HKKN 023	490,00	✓
24		HKKN 024	494,00	✓
25		HKKN 025	498,00	✓
26		HKKN 026	509,00	✓
27		HKKN 027	509,00	✓
28		HKKN 028	509,00	✓
29		HKKN 029	517,00	✓
30		HKKN 030	517,00	✓
31		HKKN 031	606,00	✓
32		HKKN 032	608,00	✓
33		HKKN 033	608,00	✓
34		HKKN 034	614,00	✓
35		HKKN 035	617,00	✓
36		HKKN 036	695,00	✓

		Art. nr.	DKK	Lager
37		HKKN 037	695,00	✓
38		HKKN 038	698,00	✓
39		HKKN 039	702,00	✓
40		HKKN 040	705,00	✓
41		HKKN 041	838,00	✓
42		HKKN 042	844,00	✓
43		HKKN 043	844,00	✓
44		HKKN 044	844,00	✓
45		HKKN 045	846,00	✓
46		HKKN 046	905,00	✓
47		HKKN 047	913,00	✓
48		HKKN 048	913,00	✓
49		HKKN 049	917,00	✓
50		HKKN 050	947,00	✓
51		HKKN 051	1.046,00	✓
52		HKKN 052	1.074,00	✓
53		HKKN 053	1.098,00	✓
54		HKKN 054	1.155,00	✓
55		HKKN 055	1.165,00	✓
56		HKKN 056	1.199,00	✓
57		HKKN 057	1.222,00	÷
58		HKKN 058	1.246,00	÷
59		HKKN 059	1.283,00	÷
60		HKKN 060	1.291,00	✓

## CENTRERSTIFT





Størrelse	Art. nr.	DKK	Lager
Ø 12 - 60 mm	ZAK 075	81,00	✓



HKK kernebor HM 61 -150 mm med 32 mm med Weldonskaft.

Skæredybde 30 mm.

	Art. nr.	DKK	Lager
61	HKK 061	1.335,00	÷
62	HKK 062	1.380,00	÷
63	HKK 063	1.439,00	÷
64	HKK 064	1.488,00	÷
65	HKK 065	1.536,00	✓
66	HKK 066	1.666,00	÷
67	HKK 067	1.699,00	÷
68	HKK 068	1.733,00	÷
69	HKK 069	1.762,00	÷
70	HKK 070	1.815,00	✓
71	HKK 071	1.836,00	÷
72	HKK 072	1.854,00	÷
73	HKK 073	1.891,00	÷
74	HKK 074	1.921,00	÷
75	HKK 075	1.940,00	✓
76	HKK 076	1.977,00	÷
77	HKK 077	2.009,00	÷
78	HKK 078	2.066,00	÷
79	HKK 079	2.076,00	÷
80	HKK 080	2.148,00	✓
81	HKK 081	2.206,00	÷
82	HKK 082	2.281,00	÷
83	HKK 083	2.333,00	÷
84	HKK 084	2.402,00	÷
85	HKK 085	2.492,00	✓

	Art. nr.	DKK	Lager
86	HKK 086	2.521,00	÷
87	HKK 087	2.559,00	÷
88	HKK 088	2.677,00	÷
89	HKK 089	2.696,00	÷
90	HKK 090	2.832,00	✓
91	HKK 091	3.010,00	÷
92	HKK 092	3.018,00	÷
93	HKK 093	3.040,00	÷
94	HKK 094	3.067,00	÷
95	HKK 095	3.182,00	✓
96	HKK 096	3.262,00	÷
97	HKK 097	3.326,00	÷
98	HKK 098	3.379,00	÷
99	HKK 099	3.422,00	÷
100	HKK 100	3.607,00	✓
105	HKK 105	3.867,00	÷
110	HKK 110	4.090,00	✓
115	HKK 115	4.208,00	÷
120	HKK 120	4.722,00	✓
125	HKK 125	4.964,00	÷
130	HKK 130	5.579,00	✓
135	HKK 135	6.150,00	÷
140	HKK 140	6.610,00	÷
145	HKK 145	7.210,00	÷
150	HKK 150	7.811,00	÷

**CENTRERSTIFT**





Størrelse	Art. nr.	DKK	Lager
Ø 61 - 150 mm	ZAK 090	96,00	✓



HKLN HM Kernebor 12 - 60 mm med 19 mm Combi skaft (Weldon og Nitto).

Skæredybde 55 mm.

	Art. nr.	DKK	Lager
12	HKLN 012	570,00	✓
13	HKLN 013	570,00	✓
14	HKLN 014	590,00	✓
15	HKLN 015	590,00	✓
16	HKLN 016	590,00	✓
17	HKLN 017	590,00	✓
18	HKLN 018	590,00	✓
19	HKLN 019	590,00	✓
20	HKLN 020	590,00	✓
21	HKLN 021	603,00	✓
22	HKLN 022	603,00	✓
23	HKLN 023	603,00	✓
24	HKLN 024	611,00	✓
25	HKLN 025	611,00	✓
26	HKLN 026	630,00	✓
27	HKLN 027	630,00	✓
28	HKLN 028	651,00	✓
29	HKLN 029	630,00	✓
30	HKLN 030	654,00	✓
31	HKLN 031	798,00	✓
32	HKLN 032	798,00	✓
33	HKLN 033	803,00	✓
34	HKLN 034	807,00	✓
35	HKLN 035	810,00	✓
36	HKLN 036	897,00	✓

	Art. nr.	DKK	Lager
37	HKLN 037	900,00	✓
38	HKLN 038	905,00	✓
39	HKLN 039	914,00	✓
40	HKLN 040	917,00	✓
41	HKLN 041	1.044,00	✓
42	HKLN 042	1.047,00	✓
43	HKLN 043	1.047,00	✓
44	HKLN 044	1.052,00	✓
45	HKLN 045	1.052,00	✓
46	HKLN 046	1.104,00	✓
47	HKLN 047	1.110,00	✓
48	HKLN 048	1.110,00	✓
49	HKLN 049	1.110,00	✓
50	HKLN 050	1.142,00	✓
51	HKLN 051	1.248,00	✓
52	HKLN 052	1.281,00	✓
53	HKLN 053	1.293,00	✓
54	HKLN 054	1.355,00	✓
55	HKLN 055	1.371,00	✓
56	HKLN 056	1.424,00	✓
57	HKLN 057	1.505,00	✓
58	HKLN 058	1.526,00	✓
59	HKLN 059	1.551,00	✓
60	HKLN 060	1.575,00	✓

## CENTRERSTIFT



Størrelse	Art. nr.	DKK	Lager
Ø 14 - 60 mm	ZAK 100	102,00	✓



HKL HM Kernebor 61 - 100 mm med 32 mm Weldon skaft (1 1/4").

Skæredybde 55 mm.

	Art. nr.	DKK	Lager
61	HKL 061	1.632,00	÷
62	HKL 062	1.698,00	÷
63	HKL 063	1.742,00	÷
64	HKL 064	1.799,00	÷
65	HKL 065	1.862,00	✓
66	HKL 066	1.902,00	÷
67	HKL 067	1.943,00	÷
68	HKL 068	2.016,00	÷
69	HKL 069	2.142,00	÷
70	HKL 070	2.201,00	✓
71	HKL 071	2.229,00	÷
72	HKL 072	2.270,00	÷
73	HKL 073	2.298,00	÷
74	HKL 074	2.331,00	÷
75	HKL 075	2.348,00	✓
76	HKL 076	2.396,00	÷
77	HKL 077	2.445,00	÷
78	HKL 078	2.466,00	÷
79	HKL 079	2.486,00	÷
80	HKL 080	2.523,00	✓

	Art. nr.	DKK	Lager
81	HKL 081	2.559,00	÷
82	HKL 082	2.655,00	÷
83	HKL 083	2.723,00	÷
84	HKL 084	2.789,00	÷
85	HKL 085	2.826,00	✓
86	HKL 086	2.843,00	÷
87	HKL 087	2.985,00	÷
88	HKL 088	3.099,00	÷
89	HKL 089	3.239,00	÷
90	HKL 090	3.336,00	✓
91	HKL 091	3.386,00	÷
92	HKL 092	3.480,00	÷
93	HKL 093	3.549,00	÷
94	HKL 094	3.639,00	÷
95	HKL 095	3.734,00	✓
96	HKL 096	3.831,00	÷
97	HKL 097	3.917,00	÷
98	HKL 098	3.978,00	÷
99	HKL 099	4.028,00	÷
100	HKL 100	4.077,00	✓

**CENTRERSTIFT**



Størrelse	Art. nr.	DKK	Lager
Ø 61 - 100 mm	ZAK 120	113,00	✓



HKX-L HM Kernebor 18 - 60 mm med 19 mm Weldon skaft (3/4").  
 HKX-L HM Kernebor 61 - 120 mm med 32 mm Weldon skaft (1 1/4").

Skæredybde 75 mm.

	Art. nr.	DKK	Lager
18	HKX-L 018	1.088,00	✓
19	HKX-L 019	1.088,00	✓
20	HKX-L 020	1.088,00	✓
21	HKX-L 021	1.110,00	✓
22	HKX-L 022	1.110,00	✓
23	HKX-L 023	1.110,00	✓
24	HKX-L 024	1.121,00	✓
25	HKX-L 025	1.121,00	✓
26	HKX-L 026	1.134,00	✓
27	HKX-L 027	1.134,00	✓
28	HKX-L 028	1.199,00	✓
29	HKX-L 029	1.199,00	✓
30	HKX-L 030	1.199,00	✓
31	HKX-L 031	1.469,00	✓
32	HKX-L 032	1.469,00	✓
33	HKX-L 033	1.481,00	✓
34	HKX-L 034	1.481,00	✓
35	HKX-L 035	1.481,00	✓
36	HKX-L 036	1.649,00	✓
37	HKX-L 037	1.665,00	✓
38	HKX-L 038	1.665,00	✓
39	HKX-L 039	1.674,00	✓
40	HKX-L 040	1.685,00	✓
41	HKX-L 041	1.931,00	÷
42	HKX-L 042	1.931,00	÷
43	HKX-L 043	1.931,00	÷

	Art. nr.	DKK	Lager
44	HKX-L 044	1.931,00	÷
45	HKX-L 045	1.931,00	÷
46	HKX-L 046	2.033,00	÷
47	HKX-L 047	2.033,00	÷
48	HKX-L 048	2.033,00	÷
49	HKX-L 049	2.033,00	÷
50	HKX-L 050	2.099,00	÷
51	HKX-L 051	2.339,00	÷
52	HKX-L 052	2.348,00	÷
53	HKX-L 053	2.385,00	÷
54	HKX-L 054	2.495,00	÷
55	HKX-L 055	2.528,00	÷
56	HKX-L 056	2.613,00	÷
57	HKX-L 057	2.772,00	÷
58	HKX-L 058	2.810,00	÷
59	HKX-L 059	2.855,00	÷
60	HKX-L 060	2.903,00	÷
65	HKX-L 065	3.426,00	÷
70	HKX-L 070	4.047,00	÷
75	HKX-L 075	4.322,00	÷
80	HKX-L 080	4.644,00	÷
90	HKX-L 090	6.153,00	÷
100	HKX-L 100	7.454,00	÷
110	HKX-L 110	8.045,00	÷
120	HKX-L 120	8.421,00	÷

## CENTRERSTIFT



Størrelse	Art. nr.	DKK	Lager
Ø 18 - 60 mm	ZAK 225	200,00	✓
Ø 61 - 120 mm	ZAK 245	222,00	÷





HKE-L HM Kernebor 20 - 60 mm med 19 mm Weldon skaft (3/4").  
HKE-L HM Kernebor 61 - 120 mm med 32 mm Weldon skaft (1 1/4").

Skæredybde 110 mm.

	Art. nr.	DKK	Lager
18	HKE-L 018	1.291,00	√
20	HKE-L 020	1.291,00	√
21	HKE-L 021	1.291,00	√
22	HKE-L 022	1.291,00	√
23	HKE-L 023	1.291,00	√
24	HKE-L 024	1.291,00	√
25	HKE-L 025	1.291,00	√
26	HKE-L 026	1.409,00	√
27	HKE-L 027	1.409,00	√
28	HKE-L 028	1.409,00	√
29	HKE-L 029	1.409,00	√
30	HKE-L 030	1.409,00	√
31	HKE-L 031	1.718,00	√
32	HKE-L 032	1.718,00	√
33	HKE-L 033	1.721,00	√
34	HKE-L 034	1.721,00	√
35	HKE-L 035	1.721,00	√
36	HKE-L 036	1.977,00	√
37	HKE-L 037	1.977,00	√
38	HKE-L 038	1.977,00	√
39	HKE-L 039	1.977,00	√
40	HKE-L 040	1.977,00	√
41	HKE-L 041	2.017,00	÷
42	HKE-L 042	2.017,00	√
43	HKE-L 043	2.017,00	÷

	Art. nr.	DKK	Lager
44	HKE-L 044	2.017,00	√
45	HKE-L 045	2.395,00	√
46	HKE-L 046	2.395,00	÷
47	HKE-L 047	2.395,00	÷
48	HKE-L 048	2.395,00	÷
49	HKE-L 049	2.395,00	÷
50	HKE-L 050	2.733,00	√
51	HKE-L 051	2.859,00	÷
52	HKE-L 052	2.958,00	÷
53	HKE-L 053	3.067,00	÷
54	HKE-L 054	3.149,00	÷
55	HKE-L 055	3.237,00	÷
56	HKE-L 056	3.356,00	÷
57	HKE-L 057	3.440,00	÷
58	HKE-L 058	3.512,00	÷
59	HKE-L 059	3.579,00	÷
60	HKE-L 060	3.640,00	÷
65	HKE-L 065	4.256,00	÷
70	HKE-L 070	4.804,00	÷
75	HKE-L 075	5.071,00	÷
80	HKE-L 080	5.500,00	÷
90	HKE-L 090	7.094,00	÷
100	HKE-L 100	9.092,00	÷
110	HKE-L 110	9.726,00	÷
120	HKE-L 120	10.175,00	÷

## CENTRERSTIFT





Størrelse	Art. nr.	DKK	Lager
Ø 20 - 120 mm	ZAK 275	267,00	√



HKK-F HM Kernebor 14 -60 mm med FEIN QuickIN skaft.

Skæredybde 35 mm.

	Art. nr.	DKK	Lager
14	HKK-F 014	527,00	÷
15	HKK-F 015	535,00	÷
16	HKK-F 016	535,00	÷
17	HKK-F 017	535,00	÷
18	HKK-F 018	542,00	÷
19	HKK-F 019	557,00	÷
20	HKK-F 020	557,00	÷
21	HKK-F 021	557,00	÷
22	HKK-F 022	557,00	÷
23	HKK-F 023	557,00	÷
24	HKK-F 024	591,00	÷
25	HKK-F 025	591,00	÷
26	HKK-F 026	591,00	÷
27	HKK-F 027	591,00	÷
28	HKK-F 028	591,00	÷
29	HKK-F 029	591,00	÷
30	HKK-F 030	602,00	÷
31	HKK-F 031	702,00	÷
32	HKK-F 032	702,00	÷
33	HKK-F 033	702,00	÷
34	HKK-F 034	702,00	÷
35	HKK-F 035	702,00	÷
36	HKK-F 036	787,00	÷
37	HKK-F 037	787,00	÷

	Art. nr.	DKK	Lager
38	HKK-F 038	787,00	÷
39	HKK-F 039	787,00	÷
40	HKK-F 040	787,00	÷
41	HKK-F 041	925,00	÷
42	HKK-F 042	925,00	÷
43	HKK-F 043	925,00	÷
44	HKK-F 044	925,00	÷
45	HKK-F 045	925,00	÷
46	HKK-F 046	986,00	÷
47	HKK-F 047	986,00	÷
48	HKK-F 048	986,00	÷
49	HKK-F 049	986,00	÷
50	HKK-F 050	1.050,00	÷
51	HKK-F 051	1.143,00	÷
52	HKK-F 052	1.184,00	÷
53	HKK-F 053	1.192,00	÷
54	HKK-F 054	1.216,00	÷
55	HKK-F 055	1.258,00	÷
56	HKK-F 056	1.291,00	÷
57	HKK-F 057	1.328,00	÷
58	HKK-F 058	1.350,00	÷
59	HKK-F 059	1.377,00	÷
60	HKK-F 060	1.409,00	÷

## CENTRERSTIFT



Størrelse	Art. nr.	DKK	Lager
Ø 14 - 60 mm	ZAK 096	135,00	✓



HKK Rail HM Kernebor 17 - 36 mm med 19 mm Weldon skaft.  
Velegnet til jernbaneskiner.

Skæredybde 30 mm.

	Art. nr.	DKK	Lager
17	HKK-R 017	661,00	÷
18	HKK-R 018	661,00	÷
19	HKK-R 019	661,00	÷
20	HKK-R 020	661,00	÷
21	HKK-R 021	698,00	÷
22	HKK-R 022	698,00	÷
23	HKK-R 023	698,00	÷
24	HKK-R 024	698,00	÷
25	HKK-R 025	698,00	÷
26	HKK-R 026	724,00	÷

	Art. nr.	DKK	Lager
27	HKK-R 027	724,00	÷
28	HKK-R 028	724,00	÷
29	HKK-R 029	724,00	÷
30	HKK-R 030	724,00	÷
31	HKK-R 031	821,00	÷
32	HKK-R 032	821,00	÷
33	HKK-R 033	821,00	÷
34	HKK-R 034	821,00	÷
35	HKK-R 035	821,00	÷
36	HKK-R 036	935,00	÷

**CENTRERSTIFT**

Størrelse	Art. nr.	DKK	Lager
Ø 12 - 60 mm	ZAK 075	81,00	✓

**SPÅNBRYDER**

Snittap med spånbrøder HSS form B M8 - M20 mm med 19mm. Weldon skaft.

	Art. nr.	Længde/mm	DIN Form B	DKK	Lager
M8	GWB 008	90	371	326,00	✓
M10	GWB 010	100	376	346,00	✓
M12	GWB 012	110	376	351,00	✓
M16	GWB 016	110	376	374,00	✓
M18	GWB 018	125	376	380,00	✓
M20	GWB 020	140	376	502,00	✓



Beskrivelse	Art. nr.	DKK	Lager
KEYLESS adapter med indvendig smøring. MK 2 med 19 mm Weldon skaft.	ZSS 200	1.708,00	✓
KEYLESS adapter med indvendig smøring. MK 3 med 19 mm Weldon skaft.	ZSS 300	1.855,00	✓
Adapter til manuel smøring. MK 2 med 19 mm Weldon skaft.	ZIA 219M	858,00	✓
Adapter til manuel smøring. MK 3 med 19 mm Weldon skaft.	ZIA 319M	981,00	✓
Adapter til manuel smøring. MK 4 med 19 mm Weldon skaft.	ZIA 419M	1.287,00	✓
Adapter til manuel smøring. MK 3 med 32 mm Weldon skaft.	ZIA 332M	1.073,00	✓
Adapter til manuel smøring. MK 4 med 32 mm Weldon skaft.	ZIA 432M	1.596,00	✓
Adapter med indvendig smøring. MK 2 med 19 mm Weldon skaft.	ZIA 219-KN	1.596,00	✓
Adapter med indvendig smøring. MK 3 med 19 mm Weldon skaft.	ZIA 319-KN	1.657,00	✓
Adapter med indvendig smøring. MK 3 med 32 mm Weldon skaft.	ZIA 332-KN	1.900,00	✓
Adapter med indvendig smøring. MK 4 med 19 mm Weldon skaft.	ZIA 419-KN	2.114,00	✓
Adapter med indvendig smøring. MK 4 med 32 mm Weldon skaft.	ZIA 432-KN	2.329,00	✓



Beskrivelse			Art. nr.	DKK	Lager
Quick change system Størrelse 2 Holder MK 2 Gevind M 5 - M 16			GSW 222	2.218,00	÷
Quick change system Størrelse 1 Holder MK 3 Gevind M 3 - M 14			GSW 331	1.782,00	÷
Quick change system Størrelse 2 Holder MK 3 Gevind M 5 - M 24			GSW 332	2.263,00	÷
Quick change system Størrelse 3 Holder MK 3 Gevind M 12 - M 30			GSW 333	4.386,00	÷
Quick change system Størrelse 2 Holder MK 4 Gevind M 5 - M 24			GSW 442	4.226,00	÷
Quick change system Størrelse 3 Holder MK 4 Gevind M 12 - M 30			GSW 443	4.776,00	÷
Quick change system Størrelse 4 Holder MK 4 Gevind M 20 - M 42			GSW 444	10.025,00	÷
Quick change indsats til gevindbor Størrelse 1					
Gevind	Skaft Ø	Firkant			
M3	3,5	2,7	GSE 103	410,00	÷
M4	4,5	3,4	GSE 104	410,00	÷
M5/M6	6,0	4,9	GSE 105	410,00	÷
M8	8,0	6,3	GSE 108	410,00	÷
M10	10	8,0	GSE 110	410,00	÷
M12	9,0	7,0	GSE 112	410,00	÷
M14	11,0	9,0	GSE 114	410,00	÷



Beskrivelse			Art. nr.	DKK	Lager
Quick change indsats til gevindbor størrelse 2					
Gevind	Skaft Ø	Firkant			
M5/M6	6	4,9	GSE 205	561,00	÷
M8	8	6,3	GSE 208	561,00	÷
M10	10	8,0	GSE 210.1	561,00	÷
M12	9	7,0	GSE 212	561,00	÷
M14	11	9,0	GSE 214	561,00	÷
M16	12	9,0	GSE 216	561,00	÷
M18	14	11,0	GSE 218	561,00	÷
M20	16	12,0	GSE 220	561,00	÷
M22/M24	18	14,5	GSE 222	561,00	÷
Quick change indsats til gevindbor størrelse 3					
Gevind	Skaft Ø	Firkant			
M14	11	9,0	GSE 314	1.297,00	÷
M16	12	9,0	GSE 316	1.297,00	÷
M18	14	11,0	GSE 318	1.297,00	÷
M20	16	12,0	GSE 320	1.297,00	÷
M22/M24	18	14,5	GSE 322	1.297,00	÷
M27	20	16,0	GSE 327	1.297,00	÷
M30	22	18,0	GSE 330	1.297,00	÷



Beskrivelse			Art. nr.	DKK	Lager
Quick change indsats til gevindbor størrelse 2					
Gevind	Skaft Ø	Firkant			
M5/M6	6	4,9	GSS 205	1.191,00	÷
M8	8	6,2	GSS 208	1.191,00	÷
M10	10	8,0	GSS 210	1.191,00	÷
M12	9	7,0	GSS 212	1.191,00	÷
M16	12	9,0	GSS 216	1.191,00	÷
M18	14	11,0	GSS 218	1.191,00	÷
M20	16	12,0	GSS 220	1.191,00	÷
M22/M24	18	14,5	GSS 222	1.191,00	÷



Beskrivelse			Art. nr.	DKK	Lager
Quick change indsats til gevindbor Størrelse 3					
Gevind	Skaft Ø	Firkant			
M12	9	7,0	GSS 312	2.719,00	÷
M14	11	9,0	GSS 314	2.719,00	÷
M16	12	9,0	GSS 316	2.719,00	÷
M18	14	11,0	GSS 318	2.719,00	÷
M20	16	12,0	GSS 320	2.719,00	÷
M22/24	18	14,5	GSS 322	2.719,00	÷
M27	20	16,0	GSS 327	2.719,00	÷
M30	22	18,0	GSS 330	2.719,00	÷
Quick change indsats til gevindbor Størrelse 4					
Gevind	Skaft Ø	Firkant			
M20	16	12,0	GSS 420	5.917,00	÷
M22/24	18	14,5	GSS 422	5.917,00	÷
M27	20	16,0	GSS 427	5.917,00	÷
M30	22	18,0	GSS 430	5.917,00	÷
M33	25	20,0	GSS 433	5.917,00	÷
M36	28	22,0	GSS 436	5.917,00	÷
M39/42	32	24,0	GSS 442	5.917,00	÷



Beskrivelse				Art. nr.	DKK	Lager
Mellemstykke med Weldon skaft						
Gevind DIN 376	Skaft Ø	Størrelse	Firkant			
M10	7	19 mm	5,5	ZGA 010	383,00	✓
M12	9	19 mm	7,0	ZGA 012	383,00	✓
M14	11	19 mm	9,0	ZGA 014	383,00	✓
M16	12	19 mm	9,0	ZGA 016	383,00	✓
M18	14	19 mm	11,0	ZGA 018	383,00	✓
M20	16	19 mm	12,0	ZGA 020	422,00	✓
M22/24	18	32 mm	14,5	ZGA 022	422,00	✓
M27	20	32 mm	16,0	ZGA 027	422,00	✓
M30	22	32 mm	18,00	ZGA 030	422,00	✓

THREAD CUTTING SYSTEMS

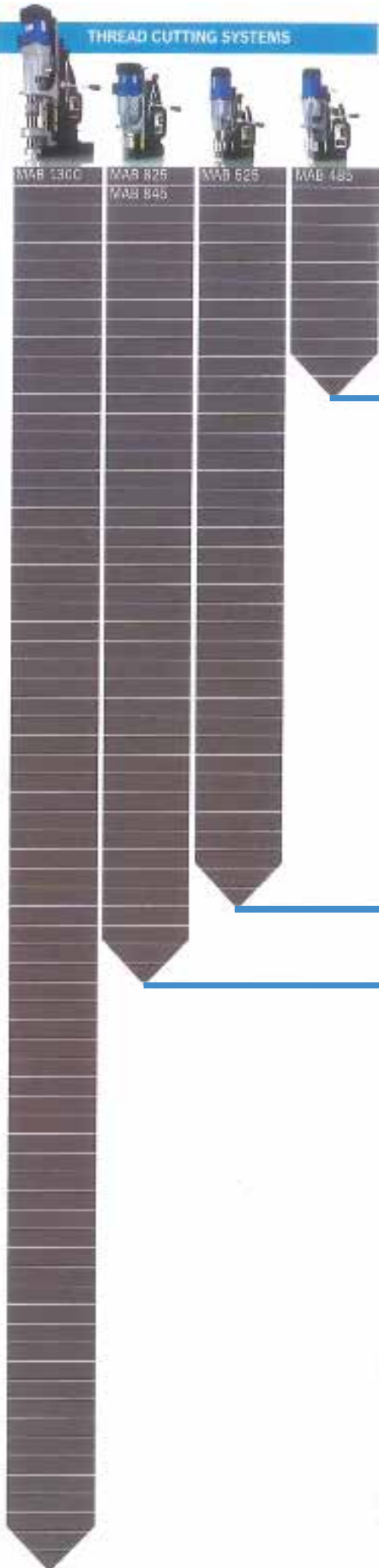

GSW





GSE



GSS

Hurtigskiftesystem	Gevind	GSE Art. nr.	GSS Art. nr.	
GSW 222 Størrelse 2 MK 2	M5/M6	GSE 205	GSS 205	
	M6		GSS 206	
	M8	GSE 208	GSS 208	
	M8		GSS 205	
	M10	GSE 210-DIN 371		
	M10	GSE 210	GSS 210	
	M12	GSE 212	GSS 212	
	M14	GSE 214	GSS 214	
GSW 331 Størrelse 1 MK 3	M4	GSE 104		
	M5/M6	GSE 105		
	M8	GSE 108		
	M10	GSE 110		
	M12	GSE 112		
	M14	GSE 114		
	GSW 332 Størrelse 2 MK 3	M5/M6	GSE 205	GSS 205
		M6		GSS206
M8		GSE 208	GSS 208	
M8			GSS 205	
M10		GSE 210.1		
M10		GSE 210	GSS 210	
M12		GSE 212	GSS 212	
M14		GSE 214	GSS 214	
*ikke egenet til MAB525 GSW 333 Størrelse 3 MK 3	M12		GSS 312	
	M14	GSE 314	GSS 314	
	M16	GSE 316	GSS 316	
	M18	GSE 318	GSS 318	
	M20	GSE 320	GSS 320	
	GSW 333 Størrelse 3 MK 3	M22/M24	GSE 322	GSS 322
		M27	GSE 327	GSS 327
		M30	GSE 330	GSS 330
GSW 442 Størrelse 2 MK 4	M5/M6	GSE 205	GSS 205	
	M6		GSS 206	
	M8	GSE 208	GSS 208	
	M8		GSS205	
	M10	GSE 210-DIN 371		
	M10	GSE 210	GSS 210	
	M12	GSE 212	GSS 212	
	M14	GSE214	GSS214	
	M16	GSE 216	GSS 216	
	M18	GSE 218	GSS 218	
	M20	GSE 220	GSS 220	
	M22/24	GSE222	GSS 222	
GSW 443 Størrelse 3 MK 4	M12		GSS 312	
	M14	GSE 314	GSS 314	
	M16	GSE 316	GSS 316	
	M18	GSE 318	GSS 318	
	M20	GSE 320	GSS 320	
	M22/24	GSE 322	GSS 322	
	M27	GSE 327	GSS 327	
	M30	GSE 330	GSS 330	
GSW 444 Størrelse 4 MK 4	M20		GSS 420	
	M22/24		GSS 422	
	M27		GSS 427	
	M30		GSS 430	
	M33		GSS 433	
	M36		GSS 436	
	M39/42		GSS 442	



	Beskrivelse	Art. nr.	DKK	Lager
	Adapter fra 32 mm Weldonskaft til 19 mm Weldonskaft	ZAP 200	538,00	✓
	Adapter med Weldonskaft 19mm bruges til FEIN kernebor. Gevind M18 X 6 P1,5t	ZAF 002	683,00	÷
	Adapter med Weldonskaft 19mm til FEIN kernebor med QuickIN skaft	ZAF 003	683,00	✓
	Adapter med QuickIN skaft til Weldonskaft 19mm	ZAF 004	715,00	✓
	Adapter med NITTO One Thoch skaft til Kernebor med Weldonskaft	ZAF 005	741,00	✓
	107 mm centrerstift til adapter ZAF 004 og ZAF 005	ZAK 107	270,00	✓
	Borepatron adapter Weldonskaft 19 mm 1/2" x 20 UNF	ZAP 100	220,00	✓
	Weldonskaft forlænger 80 mm Weldonskaft 19 mm	ZAP 300	1.206,00	✓
	HSS-forsænker 90° med 3 skær, 19 mm Weldonskaft, Ø 10 - 40 mm	ZSE 040	1.398,00	✓
	HSS-forsænker 90° med 3 skær, 19 mm Weldonskaft, Ø 15 - 50 mm	ZSE 050	1.974,00	✓
	Pumpe flaske	ZKP 100	220,00	✓
	Sikkerhedskæde til kerneboremaskine	ZSK 001	314,00	✓

## KANTFRÆSER



SKF 025

Optagen effekt (KW)	1.100
Volt	220-240
Omdrejningstal (o/min)	2.850
Fræserbredde (mm.)	15
Håndføring	✓
Trinløs vinkel indstilling	15-60°
Sikkerhed	Automatisk sluk ved overbelastning
Vægt (kg)	22,0
Kantfræser (2 rækker) med 10 HM-platte	✓
Art. nr.	SKF 025
DKK	23.715,00
Lager	÷

## KANTFRÆSER

## AUTOCUT



AutoCut 500

Optagen effekt (Watt)	1.100
Volt	380
Omdrejningstal (o/min)	2750
Fræserbredde (mm)	max. 30
Automatisk føring (mm/min)	max. 500
Trinløs vinkel indstilling	15-60°
Fræser hoved med HM platter	1 stk.
Vægt (kg)	50,0
Art. nr.	AutoCut 500
DKK	79.100,00
Lager	÷

### Tilbehør til SKF 025



	Art. nr.	DKK	Lager
HM-platte	SHM 800	175,00	÷
Kantfræser uden HM platter	ZFR 250	4.887,00	÷

### Tilbehør til AutoCut 500



	Art. nr.	DKK	Lager
Hoved til 6 HM-platter	ZFR 500	5.704,00	÷
HM-platte	SHM 400	201,00	÷

**KANTFRÆSER**
**EKF**

EKF Serien

Motor effekt (Watt)		1.500
Volt		220-240
Omdrejningstal (o/min)		6.000
Vinkel (grader) og fræserbredde (mm.)		30° 0-5
Vinkel (grader) og fræserbredde (mm.)		45° 0-6
Radius (mm.)		R 2,5
Vægt (kg)		4,6
Art. nr.	30° 45° R 2,5	EKF 300.3 EKF 450.3 EKF 452.3
DKK	30° 45° R 2,5	7.950,00 7.950,00 9.150,00
Lager		√

**EKF**

EKF 530 og 545

EKF Serien	530	545
Motor effekt (Watt)	1.800	1.800
Volt	230	230
Omdrejningstal (o/min) Elektronisk hastighedsregulering med fuld styreelektronik	1.850-3.350	1.850-3.350
Vinkel (° grader)	30°	45°
Fræserbredde (mm.)	0-12	0-12
Fræserhoved	ZFR 530	ZFR 545
Fræsertype	SHM 900 og SHM 900 E	SHM 900 og SHM 900 E
Tilspænding	Manuel	Manuel
Størrelse (HxBxL) i mm.	300 x 350 x 375	300 x 350 x 375
Vægt (kg)	9,3	9,3
Art. nr.	EKF 530	EKF 545
DKK	17.800,00	17.800,00
Lager	÷	÷

**EKF**

EKF 630 og 645

EKF Serien	630	645
Motor effekt (Watt)	2.300	2.300
Volt	230	230
Omdrejningstal (o/min) Elektronisk hastighedsregulering med fuld styreelektronik	1.600-3.000	1.600-3.000
Vinkel (° grader)	30°	45°
Fræserbredde (mm.)	0-15	0-15
Fræserhoved	ZFR 630	ZFR 645
Fræsertype	SHM 900 og SHM 900 E	
Tilspænding	Manuel	Manuel
Størrelse (HxBxL) i mm.	300 x 350 x 400	300 x 350 x 400
Vægt (kg)	10,2	10,2
Art. nr.	EKF 630	EKF 645
DKK	20.300,00	20.300,00
Lager	÷	÷



Beskrivelse	Art. nr.	DKK	Lager
Fræse værktøj til 30° EKF 300.3	ZFR 300.3	1.782,00	✓
Fræse værktøj til 45° EKF 450.3	ZFR 450.3	1.782,00	✓
Fræse værktøj til R 2,5 EKF 452.3	ZFR 452.3	2.034,00	✓
HM-platte til 30° og 45°	SHM 200	100,00	✓
HM-platte - Vario belagt til 30° og 45°	SHM200-E	116,00	✓
HM-platte til R 2,5 mm	SHM 202	431,00	✓
Stativ til kantfræsning af små emner	ZKF 100	1.685,00	÷
Fræse værktøj til 30° EKF Serie 500	ZFR 530	6.829,00	÷
Fræse værktøj til 45° EKF Serie 500	ZFR 545	6.829,00	÷
Fræse værktøj til 30° EKF Serie 600	ZFR 630	7.651,00	÷
Fræse værktøj til 45° EKF Serie 600	ZFR 645	7.651,00	÷
HM-platte til 30° og 45° EKF serie 500/600	SHM 900	367,00	÷
HM-platte til 30° og 45° EKF serie 500/600	SHM 900 E	561,00	÷

**Profibasic**

**MBasic 300**



**Profibasic**

**MBasic 350**

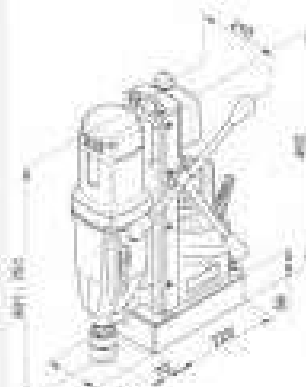

**MBasic 400**



**MBasic 450**

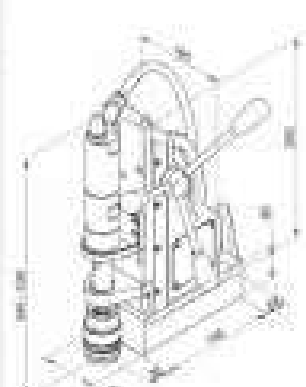

**MBasic 400**



**MBasic 450**

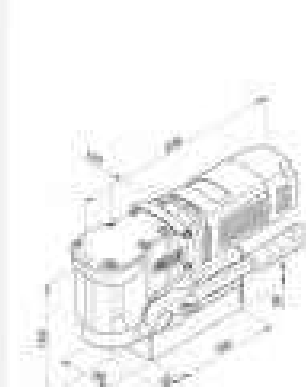

**MBasic 500**

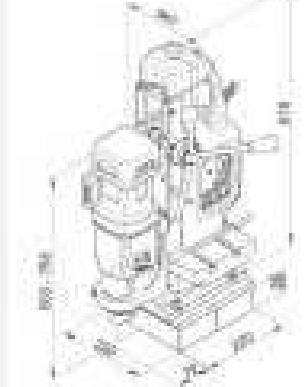

**MBasic 550**

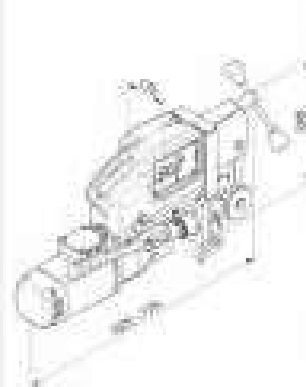

**MBasic 450**



**MBasic 500**



**MBasic 550**

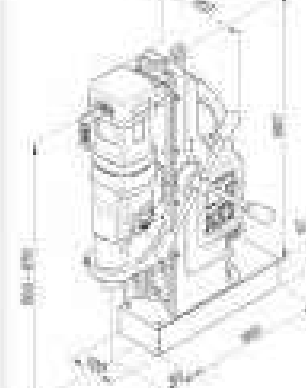

**MBasic 600**



MAD 485



MAD 525 Swivel Base

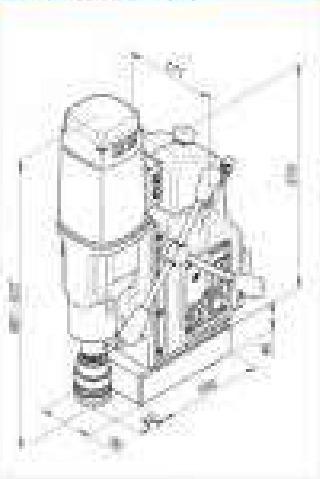

MAD 530

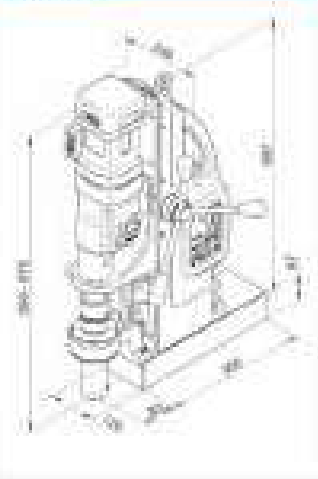

MAD 530 K

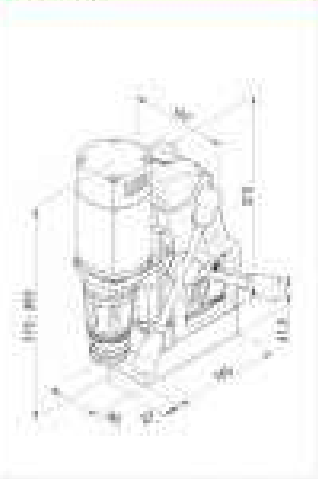

MAD 605 Swivel Base



MAD 645 Swivel Base

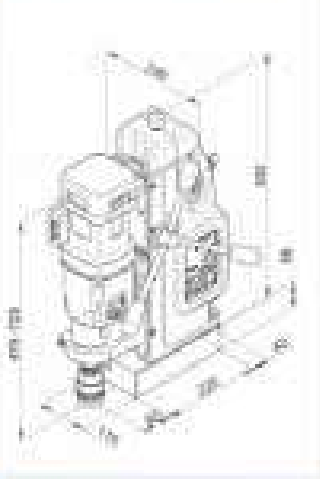

MAD 455



MAD 525



MAD 640

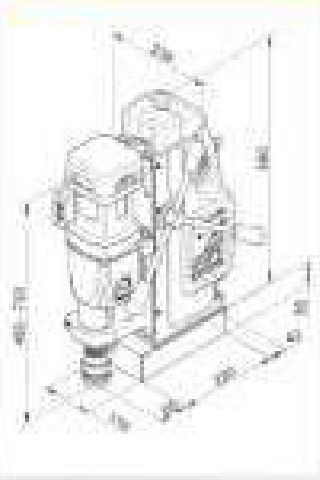

MAD 355 Swivel Base

